

Tips for Ordering

Measuring a Fitting

When measuring a fitting you need to know the distance from the outside edge of the drive edge to the outside edge of the drive edge this will become your length of duct or height of fitting.

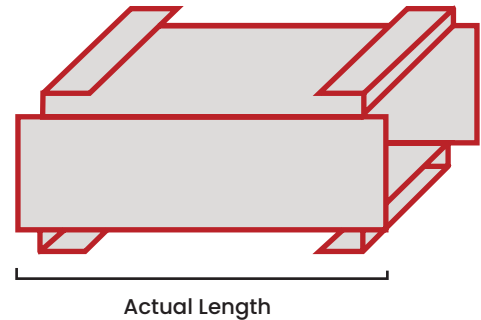

Fitting Terms

Picture every fitting in terms of:

- End 1
- End 2
- Left to Right
- Front to Back
- Long or Tall

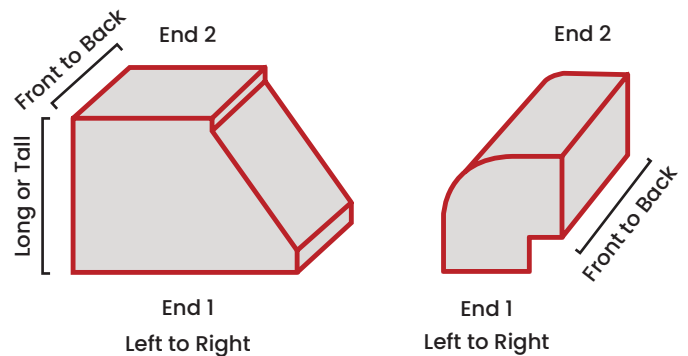

Calling Over the Phone

When calling over the phone, always have End 1 at the bottom of the page. If it is drawn horizontally turn the page.

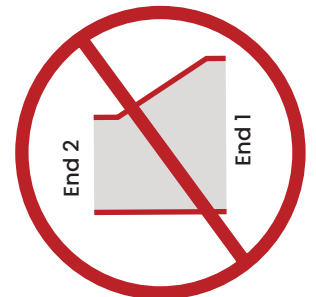
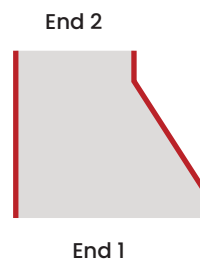

Drawing Fittings

When drawing a fitting, the first number is "Left to Right". The next number is "Front to Back".

Transition

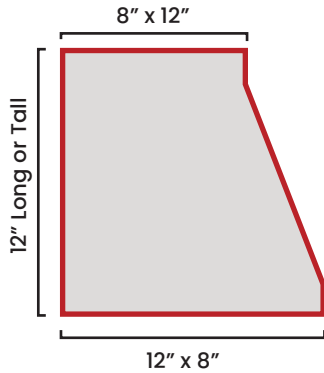

8" x 12" (Top)

- 8" is Left to Right
- 12" is Front to Back

12" x 8" (Bottom)

- 12" is Left to Right
- 8" is Front to Back

Radius 90 Elbow (Square Throat)

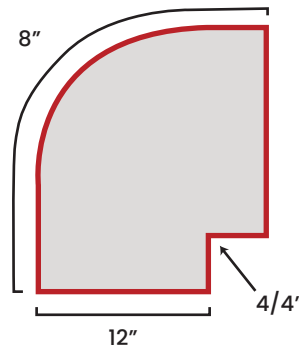

12" x 8"

- 12" is Left to Right (the side facing you)
- 8" is Front to Back

Offset

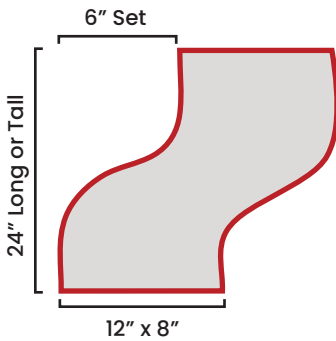

- Offsets move side to side.
- "Set" is the distance the offset moves from Left to Right.

Jump

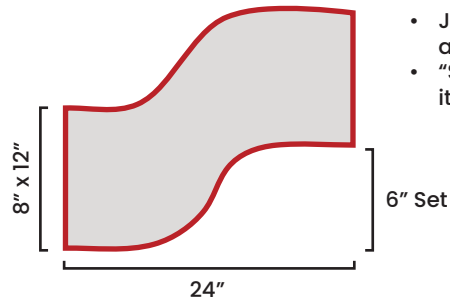

- Jumps move up and down.
- "Set" is the distance it moves up and down.

Closed Box

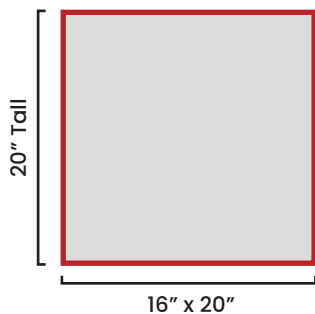

16" x 20"

- 16" is the width
- 20" is the depth

Plenum or Open Box

